

Wood firebox that blends clean design lines with ease of use. Its perfect construction linearity offers a wide variety of installation options. The screen-printed glass frames the fire and makes it the distinctive feature of the home.

MC 70/51



GENERAL FEATURES

- Heating: natural convection, radiation or optional ductable forced ventilation with the Multifuoco System® or Multifuoco System Plus,
- Structure: coated steel with closed firebox
- Firebox: Aluker®
- Hearth: Aluker®
- Opening: door in coated steel with self-cleaning ceramic glass resistant to 750°C. Opening with door, reversible
- Door profile: coated steel
- Handle: concealed detachable handle
- Primary air: manually adjustable
- Secondary air: manually adjustable
- Tertiary air: pre-determined and pre-heated
- Standard flue outlet position: top
- Fuel: wood

TECHNICAL DETAILS

- Energy efficiency class A
- Rated output max kW 11,0
- Rated thermal efficiency power % 79
- Rated consumption max kg/h 2,9
- Weight kg 140
- Model MC 70/51

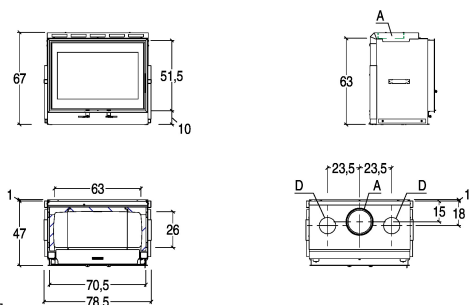

A	D
18 cm	12 cm